

Application Example: Quality Control of Injection-Molded Parts

Measuring Systems: ATOS

Keywords: Optical 3D measuring technology, mold try-out, first article inspection, form and dimension inspection of plastic parts, production control, warpage & shrinkage analysis, material thickness inspection, geometric dimensioning and tolerancing (GD&T)

The ATOS 3D digitizer, for full-field measurements of surfaces, is utilized world-wide in the injection-molding and plastic-processing industry for form and dimension inspection of injection-molded parts. Due to the 3D full-field color deviation plot, the evaluation of parts is considerably faster and much more efficient compared to conventional measuring methods. In particular, warpage and shrinkage of injection-molded parts are fast and clearly displayed speeding up mold try-out and production control. Thus, the ATOS technology allows companies to keep pace with shorter product cycles and faster lead times.

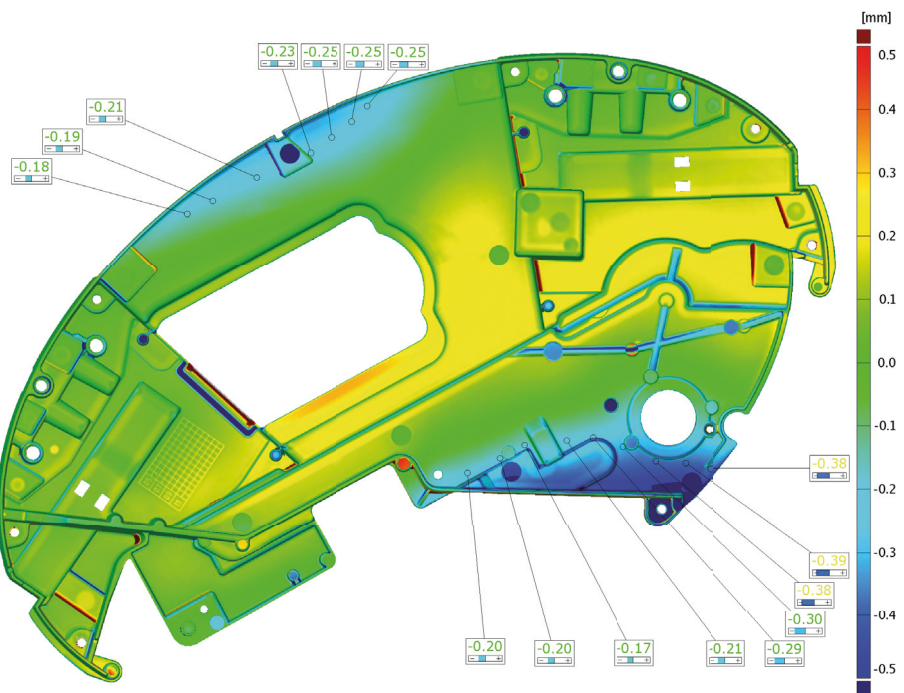

GOM mbH
Mittelweg 7-8
38106 Braunschweig
Germany
Phone +49 531 390 29 0
Fax +49 531 390 29 15
info@gom.com

GOM International AG
Bremgartnerstrasse 89B
8967 Widen
Switzerland
Phone +41 5 66 31 04 04
Fax +41 5 66 31 04 07
international@gom.com

GOM France SAS
10 Quai de la Borde - Bât A2
91130 Ris Orangis
France
Phone +33 1 60 47 90 50
Fax +33 1 69 06 63 60
info-france@gom.com

GOM UK Ltd
Business Innovation Centre
Coventry, CV3 2TX
Great Britain
Phone +44 2476 430 230
Fax +44 2476 430 001
info-uk@gom.com

GOM Branch Benelux
Interleuvenlaan 15 E
3001 Leuven
Belgium
Phone +32 16 408 034
Fax +32 16 408 734
info-benelux@gom.com

Quality Control

Today, the tools to produce injection-molded parts are often built from modified CAD data. These modifications include the incorporation of uniform and non-uniform shrink factors, adding of draft angles, parting lines etc. Best practice knowledge is also incorporated to reduce thick versus thin material areas and the possible addition of features to reduce the warping and twisting of the part. Using these basic rules, tools for simple parts can usually be calculated and milled to produce good quality parts with no further modifications needed.

However, simple parts are no longer standard today. The parts are becoming more and more complex in order to reduce mounting times. In addition, the miniaturization, elevated design demands, haptic feeling and the fitting accuracy require small manufacturing tolerances. Standard products are replaced by trendy products which need to be marketed fast. Therefore, a fast and efficient first article inspection and production control is essential for injection-molded products today.

The quality control team has to carry out a first article inspection based on the pre-production series samples and needs to monitor the quality of the product during the entire production process. For the first article inspection, the parts have to be verified quickly and reliably in order to give the green light for the production in time. These tested and complete data sets are also used as basis to validate future product modifications.

To ensure the product quality, the wearing of the mold and possible modifications of the production process have to be measured and visualized as early as possible, at minimum costs.

To measure the shape of a part on a conventional CMM (coordinate measuring machine), the part needs to be fixed and aligned to the measuring table with an individual fixture. In most cases, such a part is measured with just a few hundred measuring points leaving large areas of the part unchecked. Based on this sparse measurement information, the decision regarding the product quality and the "go" or "no go" of the production has to be taken.

If the part does not meet the expectations, the quality team has to identify the area and cause of the problem. Especially for assembly groups, consisting of multiple individual components, it is very difficult to analyse the cause of the problem. Therefore, a measuring sequence can take several days until exact guidelines of how to correct the mold can be defined.



Fig. 1: Digitizing using the ATOS SO system

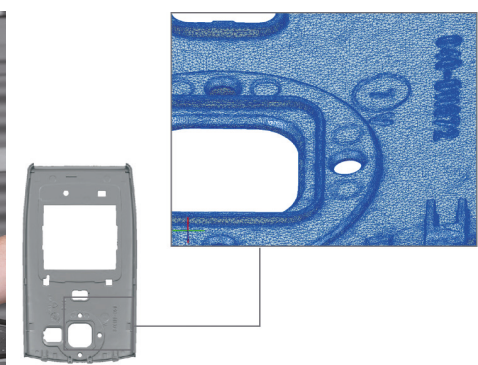

Fig. 2: ATOS measuring data of a BlackBerry cover shown as shaded point cloud and enlarged detail with curvature and accuracy dependent optimized STL data

Today, innovative companies use optical measurement technology to speed up the first article inspection process and to minimize the effort needed to ensure the product quality. Using optical systems, stable parts can be measured efficiently and with high data density (millions of measuring points) without the need to produce and to manage individual fixtures (Fig. 1, 2). Single components can be measured unmounted, or in an assembled configuration, as well as under load in order to define their shape, deformation and behavior in use.

Analysis of Shrinkage and Warpage

After measuring the component with the ATOS digitizing system the bundled ATOS Inspection Software allows immediately the professional evaluation of the data.

With the ATOS Inspection Software, warpage and shrinkage of an injection-molded part can be made visible in a colored deviation plot (Fig. 3). Due to this full-field comparison of the measured data with the CAD data (or data of a sample part) deformed areas are immediately localizable and easy to understand. The full-field 3D measurement with ATOS reveals also those problematic areas which could easily be overlooked when using only point-by-point measurement with a tactile CMM.

Local and global warpage and deviations in shape can be visualized in the ATOS Inspection Software by using different methods like 3-2-1, RPS, Best-Fit, etc. to align the measured data to the CAD data. For achieving a reliable local or global alignment, the full-field data information of the ATOS measuring system is essential as only the dense surface information offers enough measuring points for different selections. (Fig. 4).

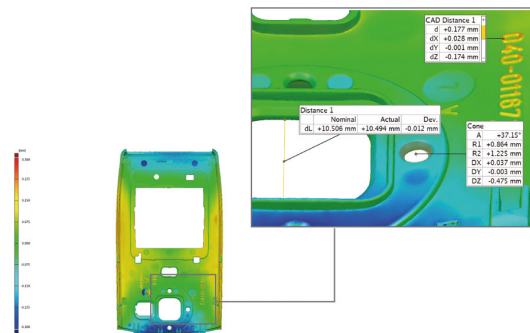

Fig. 3: Deviation of the digitized data of the sample part from the CAD data (nominal data), the ATOS Inspection Software immediately shows warpage and bending of the housing cover

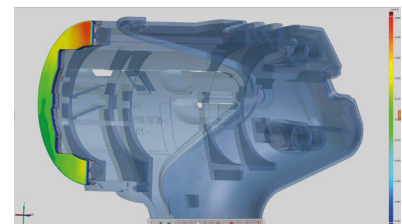

Fig. 4: The plane on the head of the drill cover is warped as shown in the color plot highlighting the deviations from CAD data.

First Article Inspection

For the classical 2D first article inspection analysis and for checking functional dimensions, the ATOS Inspection Software offers a sophisticated scalar CMM inspection tool (Fig. 5) and professional GD&T functionality (Geometric Dimensioning and Tolerancing, Fig. 6). The GD&T principles such as symbols, rules and definitions are internationally defined in the EN ISO 1101 and ASME Y14.5 standards. Thus, the verification of a part can be understood worldwide regardless of the national language of the respective inspector. Furthermore Geometric Dimensioning and Tolerancing allows for continuous quality assurance of a part starting from design up to entire production as it exactly describes the function of a part or an assembly regarding dimensions, shape and position.

The GD&T-module allows to check for flatness, cylindricity, parallelism, position, etc. with dependence of the respective geometric datum.

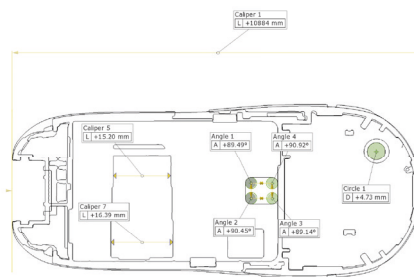

Fig. 5: 2D analysis with the ATOS CMM inspection tool

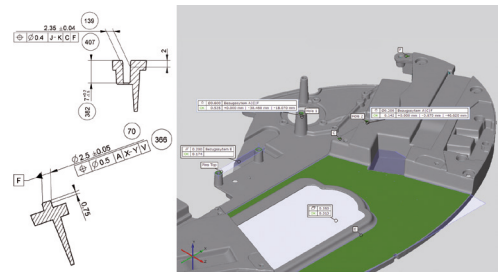

Fig. 6: Analysis of a part using the ATOS GD&T module (Geometric Dimensioning and Tolerancing)

The full-field measured data allow also to apply the material thickness inspection function of the ATOS Inspection Software to check for sink marks and material accumulation of injection-molded parts (Fig. 7). Inspection sections provide an additional detailed analysis (Fig. 8).

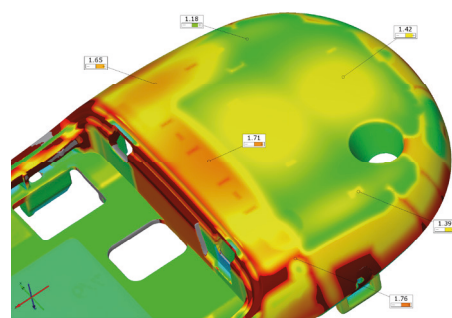

Fig. 7: Material thickness analysis in the ATOS Inspection Software

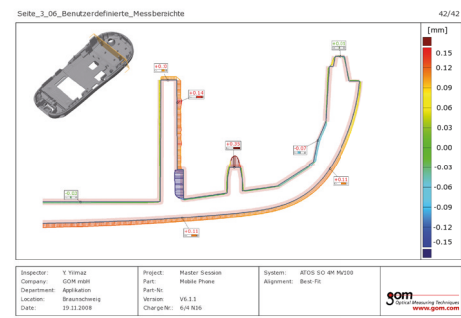

Fig. 8: Detailed 2D analysis with inspection sections

As the digitized data can be stored and reloaded easily, individual measuring values and sections can be derived and analyzed from this data at any time later on. Wear and changes in the production process are easy to verify and control. Thus, the 3D data of first article inspection and of the production accompanying control secure the quality assurance of a product over the whole life cycle.

If deviations regarding the functionality and quality of the part are understood, exact dimensional values can be derived from the digitized ATOS data and the corrections can be forwarded to the tooling manufacturer.

ATOS Stereo Camera System

Measuring systems which are used in quality control have to produce reliable and accurate data. Optical systems require two cameras in a stereo setup to fulfill this demand. Thus, the self-monitoring ATOS system reliably detects object movements during measuring and also checks the validity of the calibration. Due to the stereo setup, the individual measurements are also automatically transformed into a common object coordinate system with the help of easy applicable reference points. An interruption of the digitizing process for time consuming manual alignment of individual measurements by the user is not necessary.

The flexible ATOS system can be equipped with different measuring volumes and easily adapted within a few minutes to a wide range of measuring tasks and resolution. The fast setup of the sensor allows measurement of big parts with a large measuring volume or capturing small details with high resolution. The entire component spectrum from small to large parts can be measured with just one system (Fig. 9, 10).

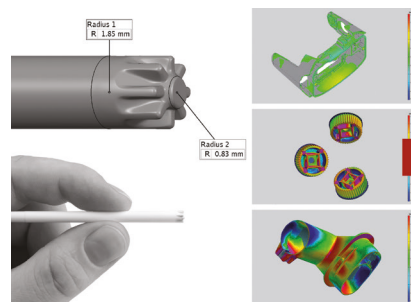

Fig. 9: Display of a small gear wheel and an angle adapter and their deviations from the respective nominal data (CAD data), measuring volume 30 x 20 mm

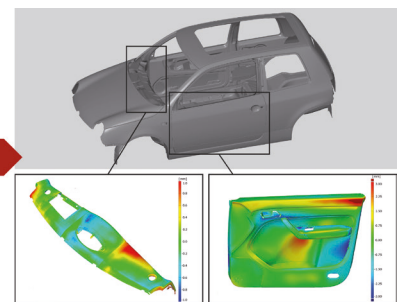

Fig. 10: Warpage of interior car parts, measuring volume 500 mm

In addition, the GOM Touch Probe combines measuring of difficult to access areas with measuring freeform surfaces of complex components within one system (Fig. 11). The ATOS sensor in this case is used as an optical tracking device for the hand-held Touch Probe for live inspection of primitives, point deviations to CAD, etc. (Fig. 12).



Fig. 11: GOM Touch Probe

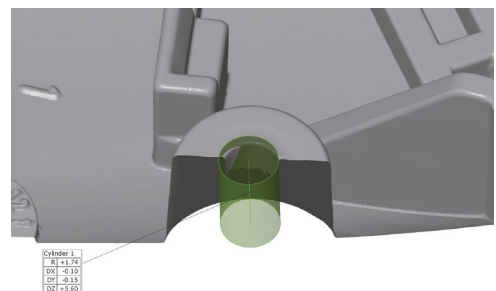

Fig. 12: Touch probed cylinder

During mold try-out - particularly in case of multi-cavity molds - often a considerable amount of samples needs to be tested. In order to save time and resources, both the data acquisition and the data evaluation requires automation. The measurement process can easily be automated using robots, rotation tables or a multi-axis positioning unit for small and medium-sized components, as can the evaluation of measurement data in the GOM inspection software. Because of the parametric software kernel, there is no longer any difference between individual and multiple evaluations, since programming with macros and scripts is eliminated.

In the standardized measurement cells of the ATOS ScanBox series, all measurement and inspection processes up to the inspection reports are executed automatically. This enables unmanned quality assurance in production environments. The different models – the series now comprises of four versions – cater for parts of different sizes. In their industrial production facilities, the measurement cells achieve higher throughput rates, since larger part volumes can be analyzed in a shorter time, and inspection processes better planned. Furthermore, the measurement cells achieve higher reproducibility and, at the same time, process reliability, since measurement and inspection processes can be deployed at different locations without an operator.



Fig. 13: In the standardized measurement cells of the ATOS ScanBox series, all measurement and inspection processes up to the inspection reports are executed automatically.

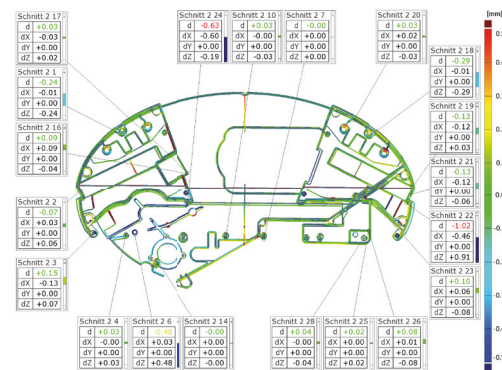

Fig. 14: Customized inspection report

Summary

High-quality digitizing systems produce data with comparable accuracy to conventional coordinate measuring machines. The advantage of the optical measurement system is its fast acquisition time, the amount of measured data and the flexible use of the system. In addition, the digitized data creates a visual 3D view of the part and its deviations from the nominal data and is also exportable for further evaluation and distribution.

An increasing number of companies are incorporating certified optical measurement systems into their measuring departments not necessarily to achieve a better measurement accuracy in the first place but to bring the measuring technology closer to production and to guarantee a comprehensive QA by a full-field component analysis. In addition, the clear colored deviation plot allows for a fast analysis of warpage and deviations and thus speeding up the optimization of the tool during mold try-out.

We would like to thank Braun, Bosch/Scintilla, Nokia, Bang & Olufsen, Volkswagen for their kind cooperation.