

Report Drill Cover



Inspector: GOM Employee

Company: GOM mbH

Department: Quality Control

Location: Braunschweig

Date: 07.06.2012

Project: Demonstration Data

Part: Drill Cover

Part no.: 1

Version: -/-

Charge no.: 1

System: ATOS

Table of Contents

Report Drill Cover.....	1
Table of Contents.....	2
Mesh.....	3
Selection of Local Best Fit.....	4
Surface Comparison - Global Best Fit vs Local Best Fit.....	5
Surface Comparison - Global Best Fit vs Local Best Fit.....	6
Surface Compariso - Tolerances (i.O. / n.i.O.).....	7
Inspection section (X = 41,0 mm).....	8
Inspection section (X = 2,7 mm) - Detail.....	9
Material Thickness on Actual.....	10
Material Thickness - Inspection Points.....	11
Circle Inspection - Position and Diameter.....	12
Circle Inspection - Position and Diameter.....	13
Circle Inspection - Hole Pattern.....	15
2D Inspection - Scalar Dimensions.....	16
GD&T Cylindricity.....	17
GD&T Flatness.....	18

Mesh

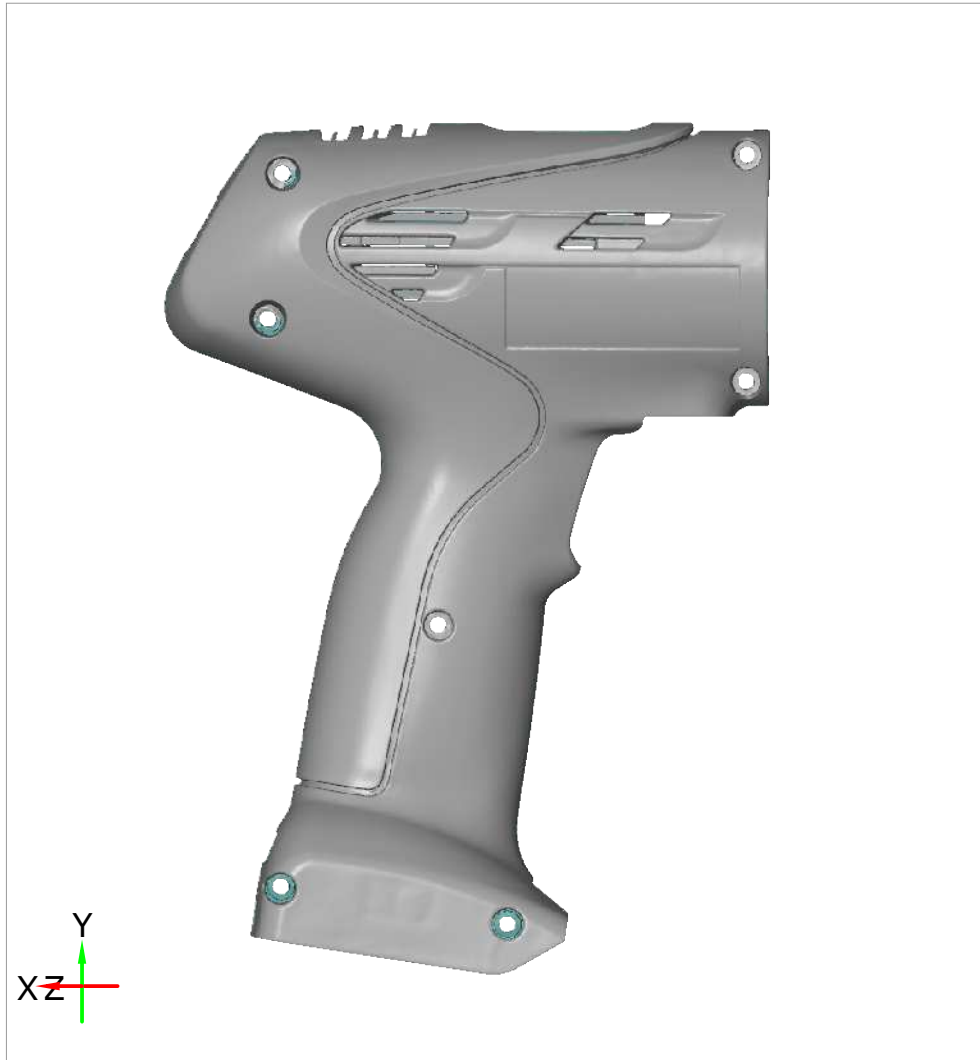

Global Best Fit

Length unit: mm

Demonstration Data Drill Cover 1 -/- 1

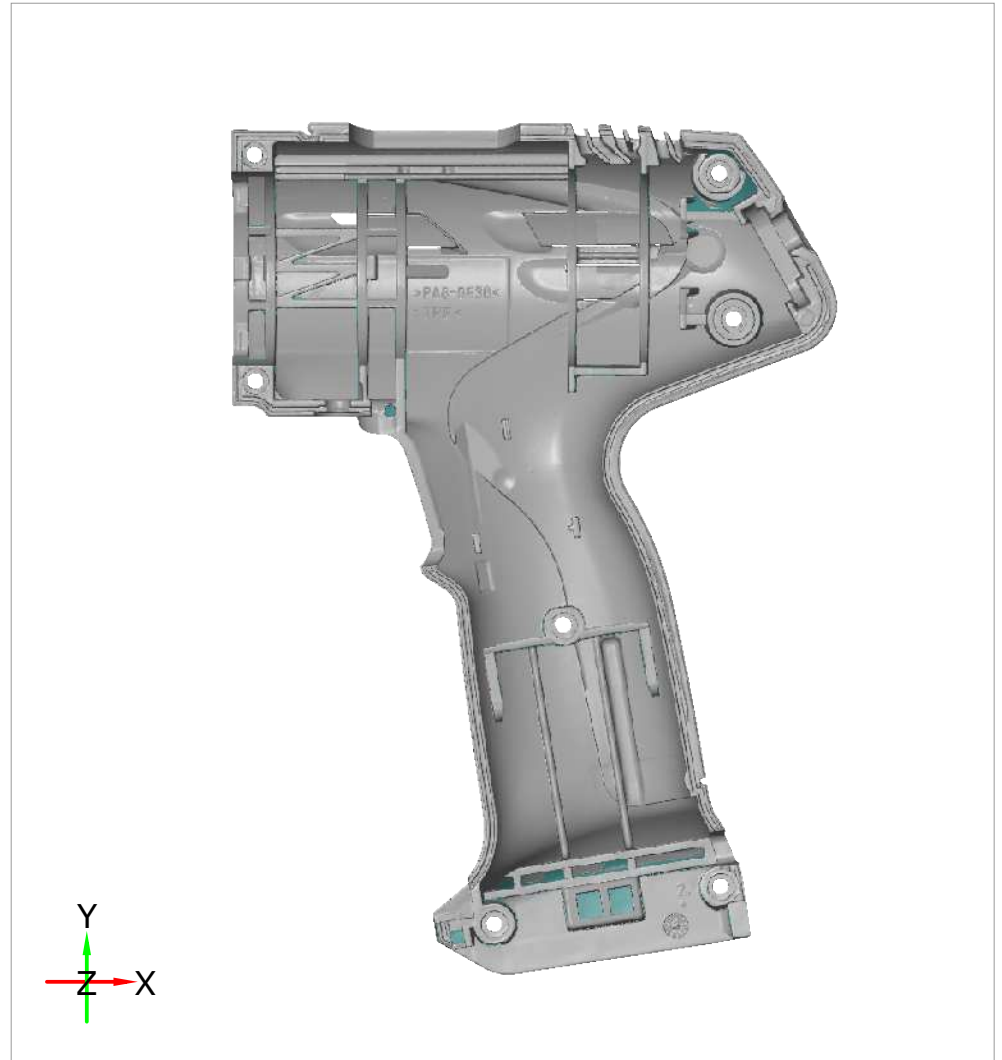

Global Best Fit

Length unit: mm

Selection of Local Best Fit



Local Best Fit

Length unit: mm

Demonstration Data Drill Cover 1 -/- 1

4/18

Surface Comparison - Global Best Fit vs Local Best Fit

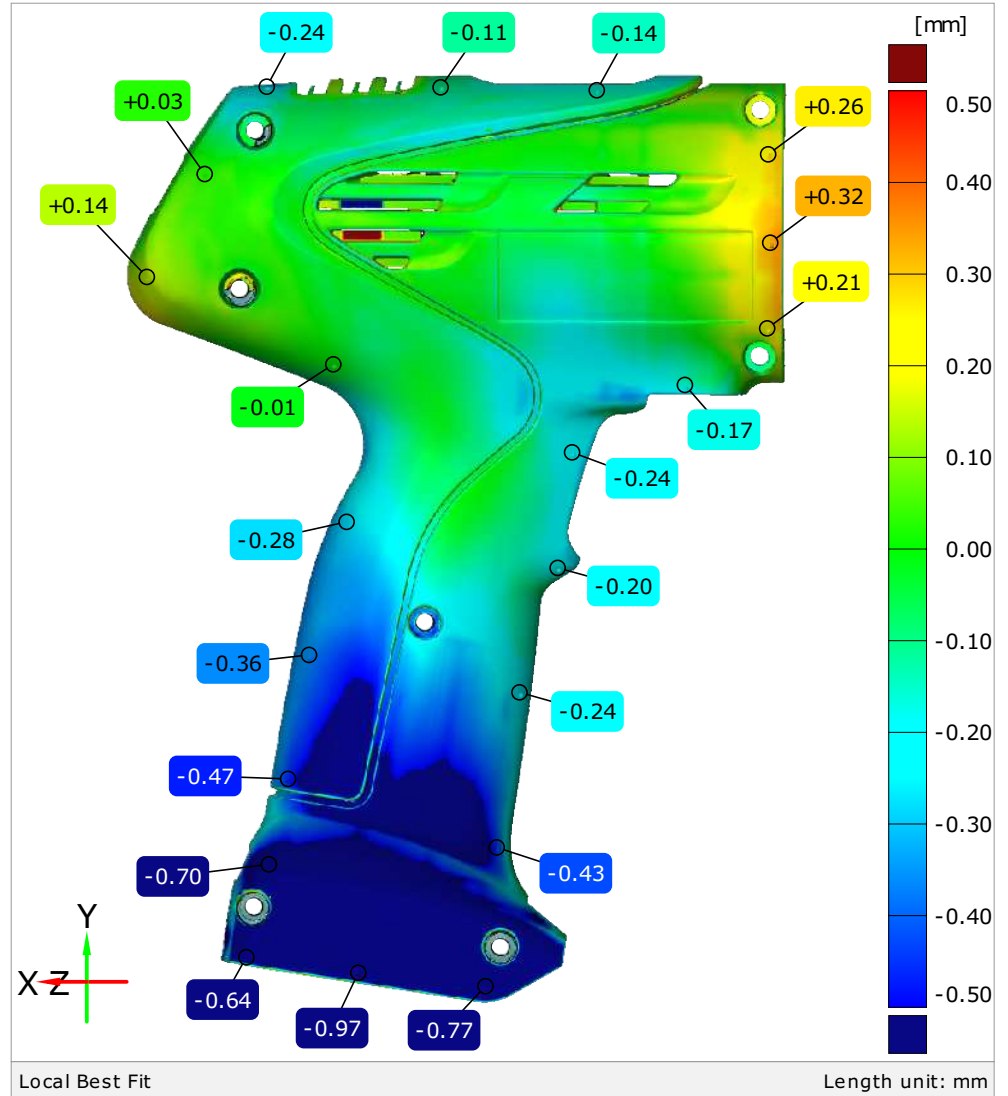
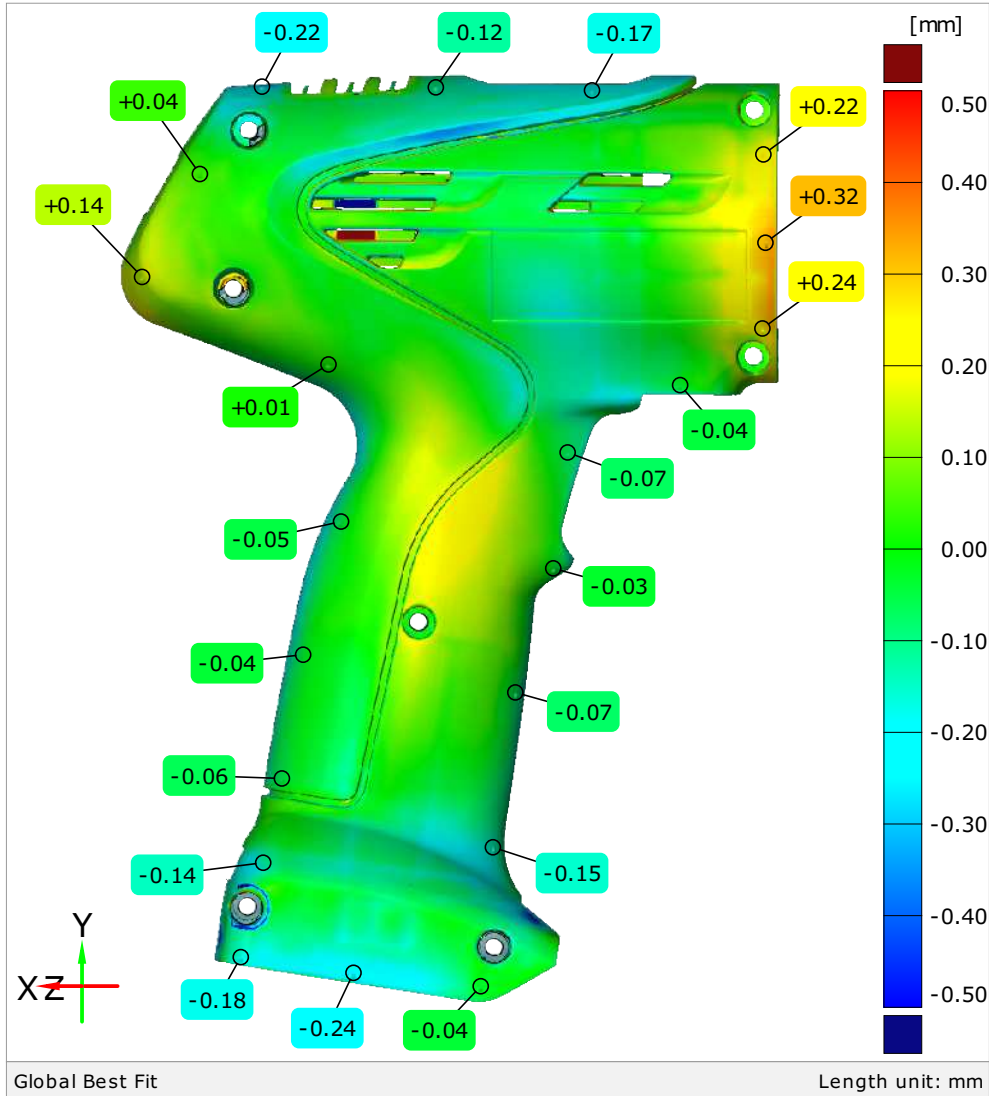

Demonstration Data Drill Cover 1 -/- 1

5/18

Surface Comparison - Global Best Fit vs Local Best Fit

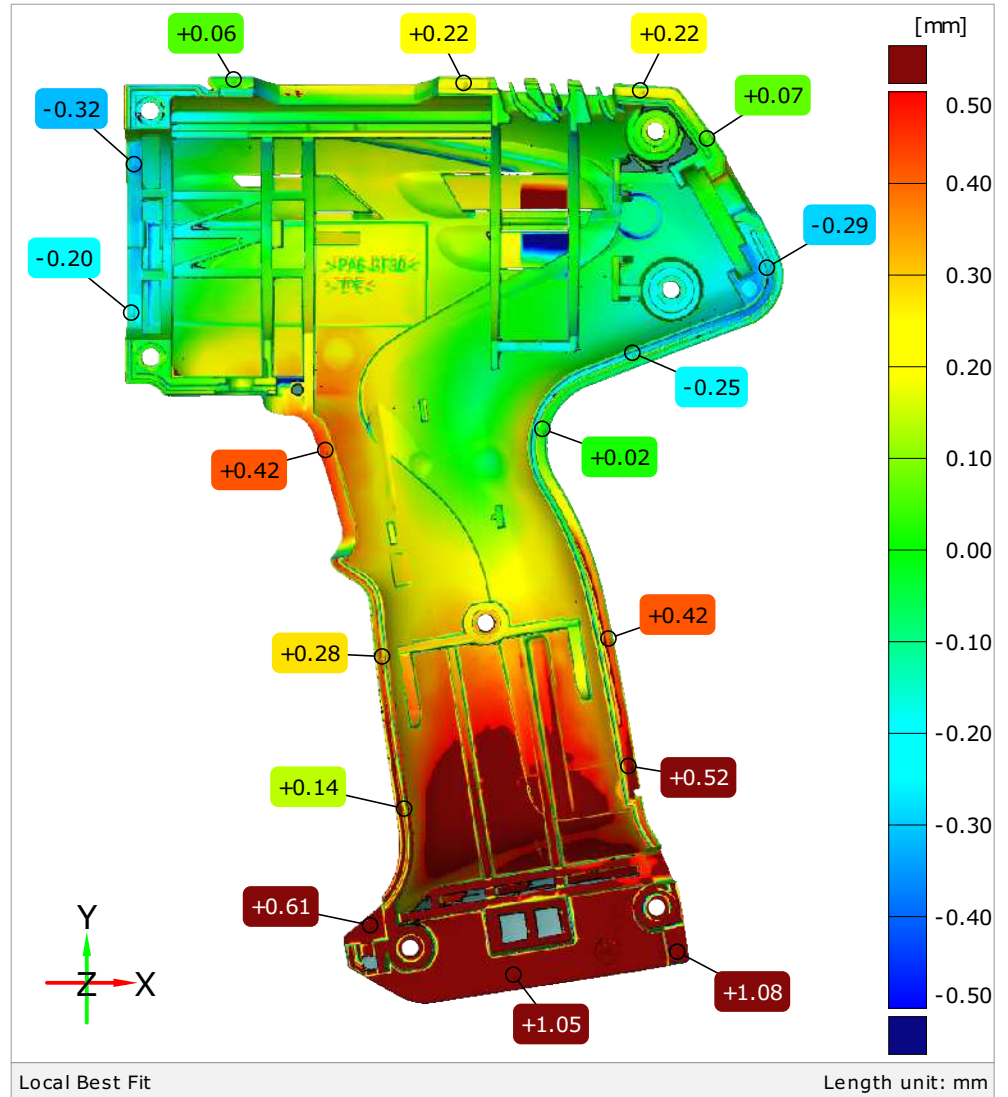
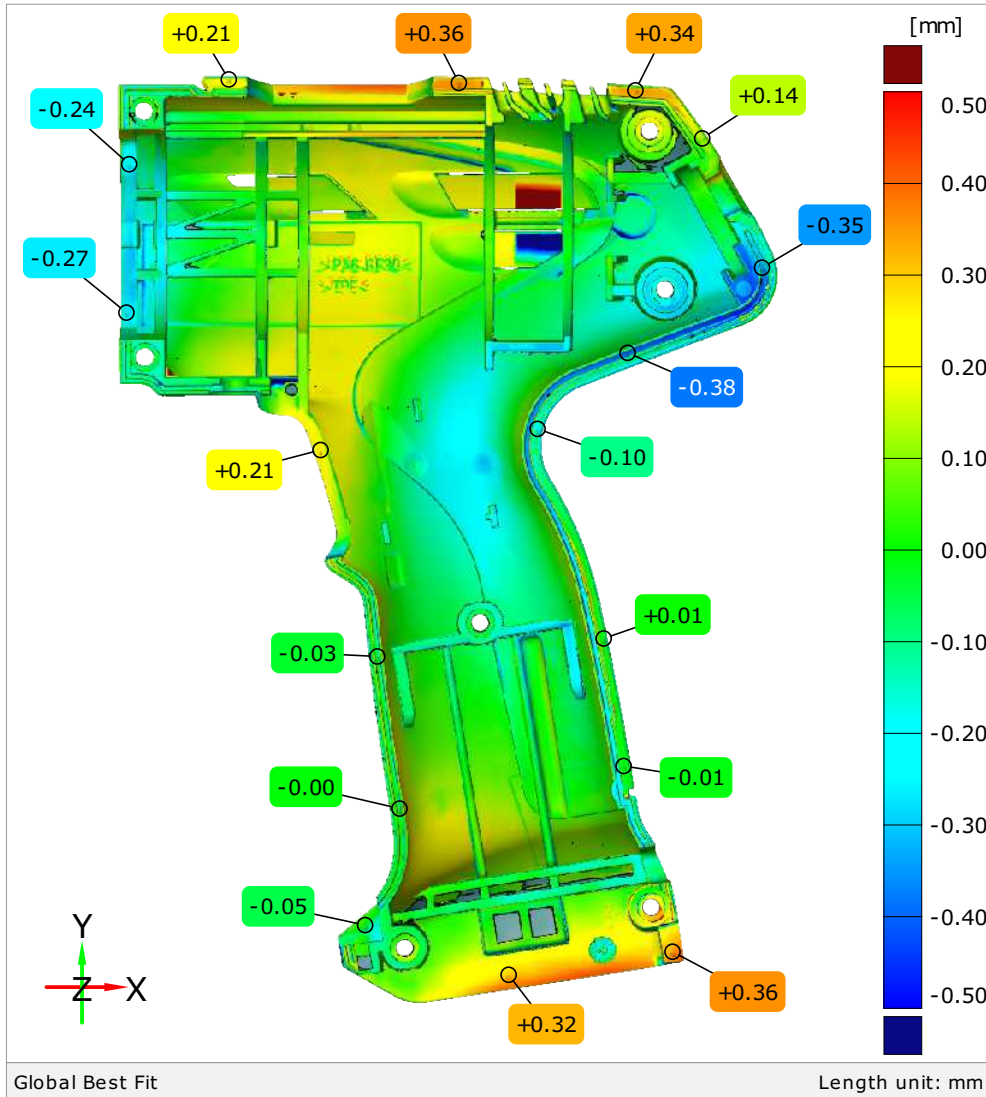

Surface Compariso - Tolerances (i.O. / n.i.O.)

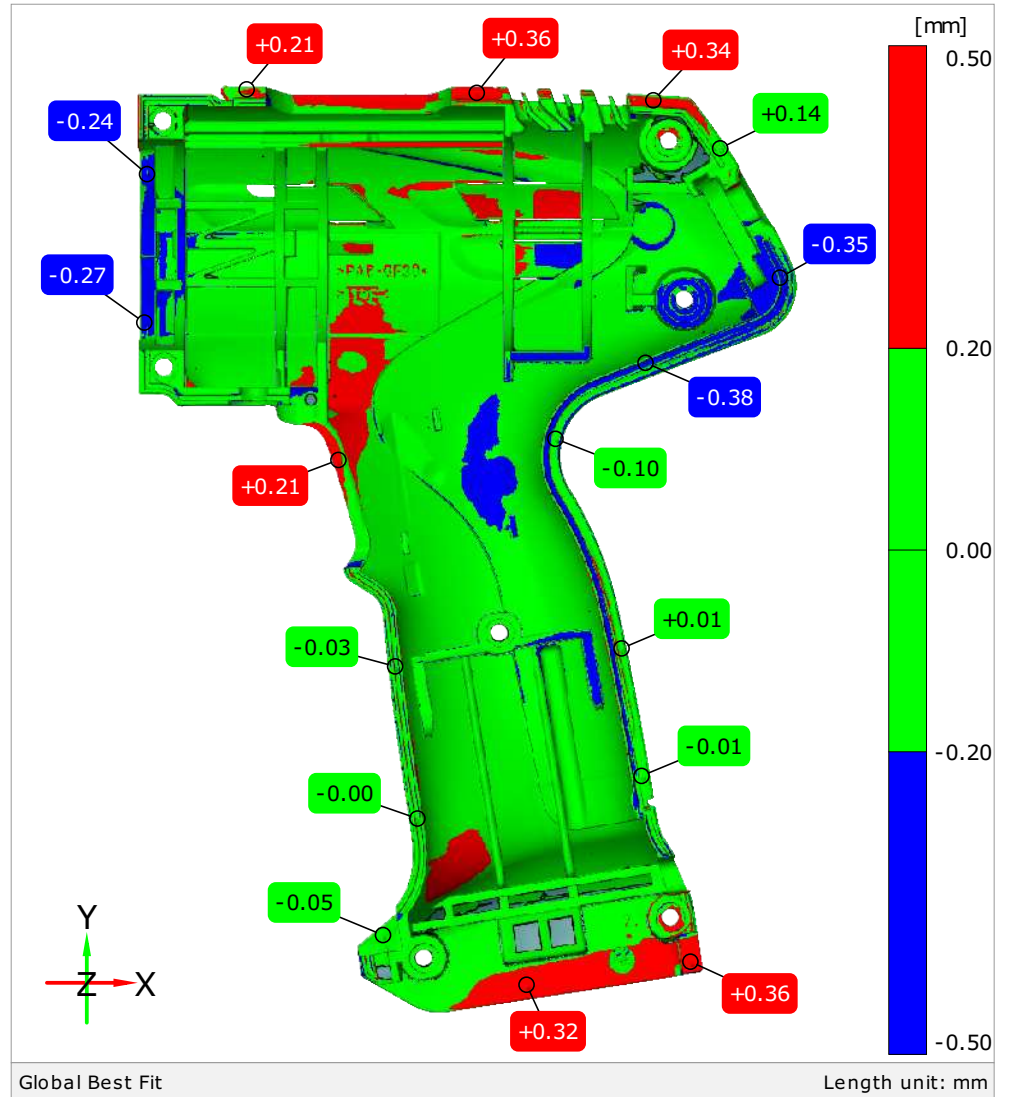
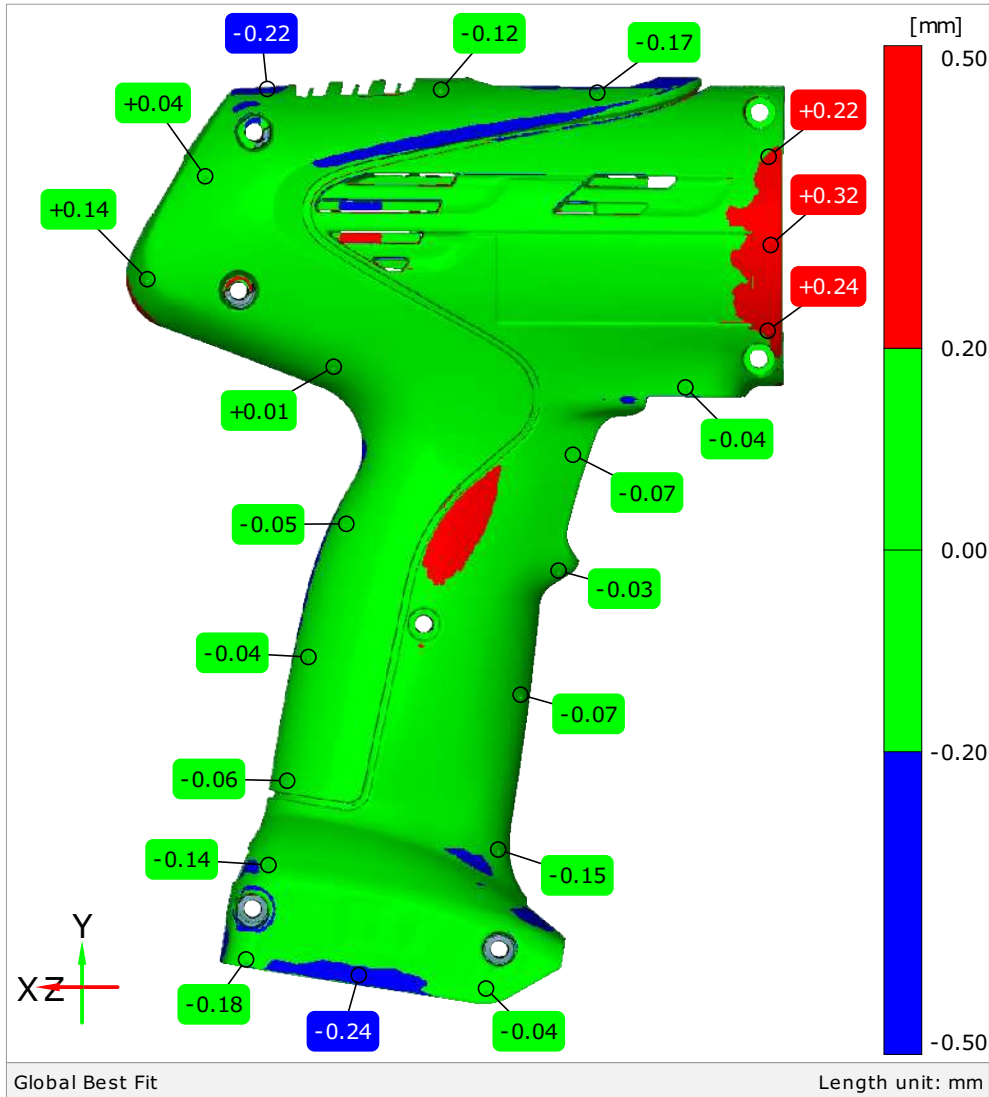

Inspection section (X = 41,0 mm)

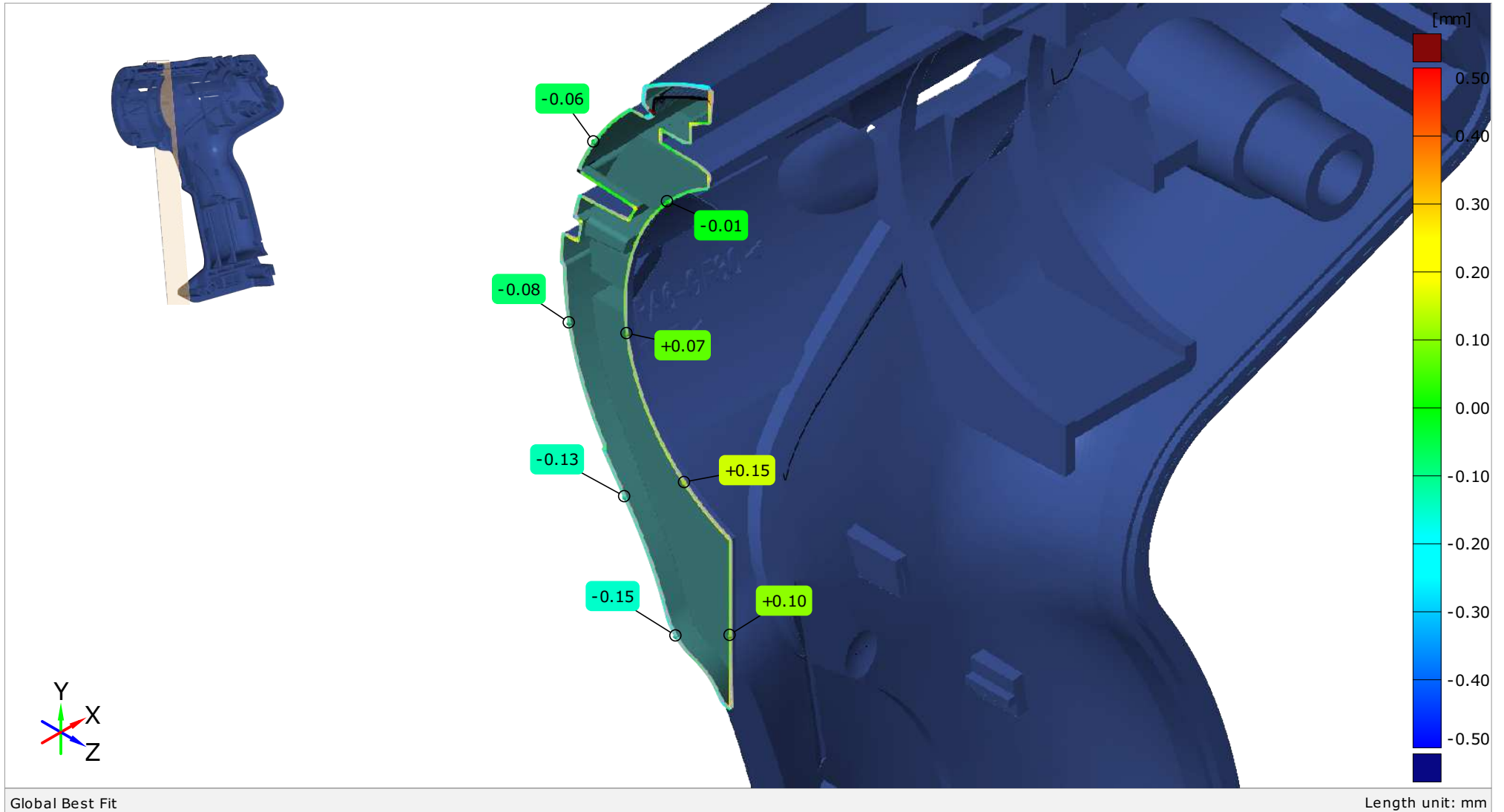

Inspection section (X = 2,7 mm) - Detail

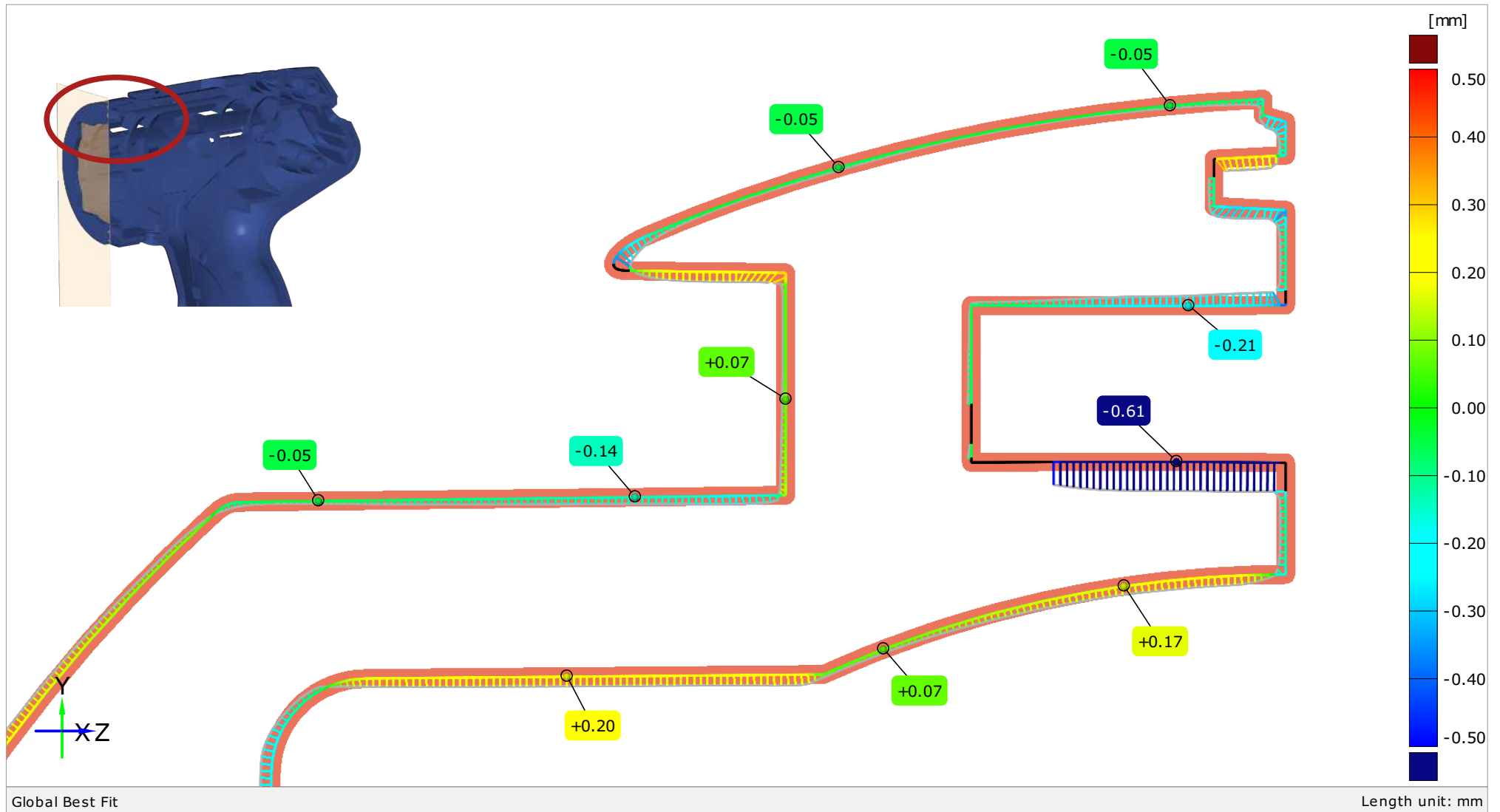

Demonstration Data Drill Cover 1 -/- 1

9/18

Material Thickness on Actual

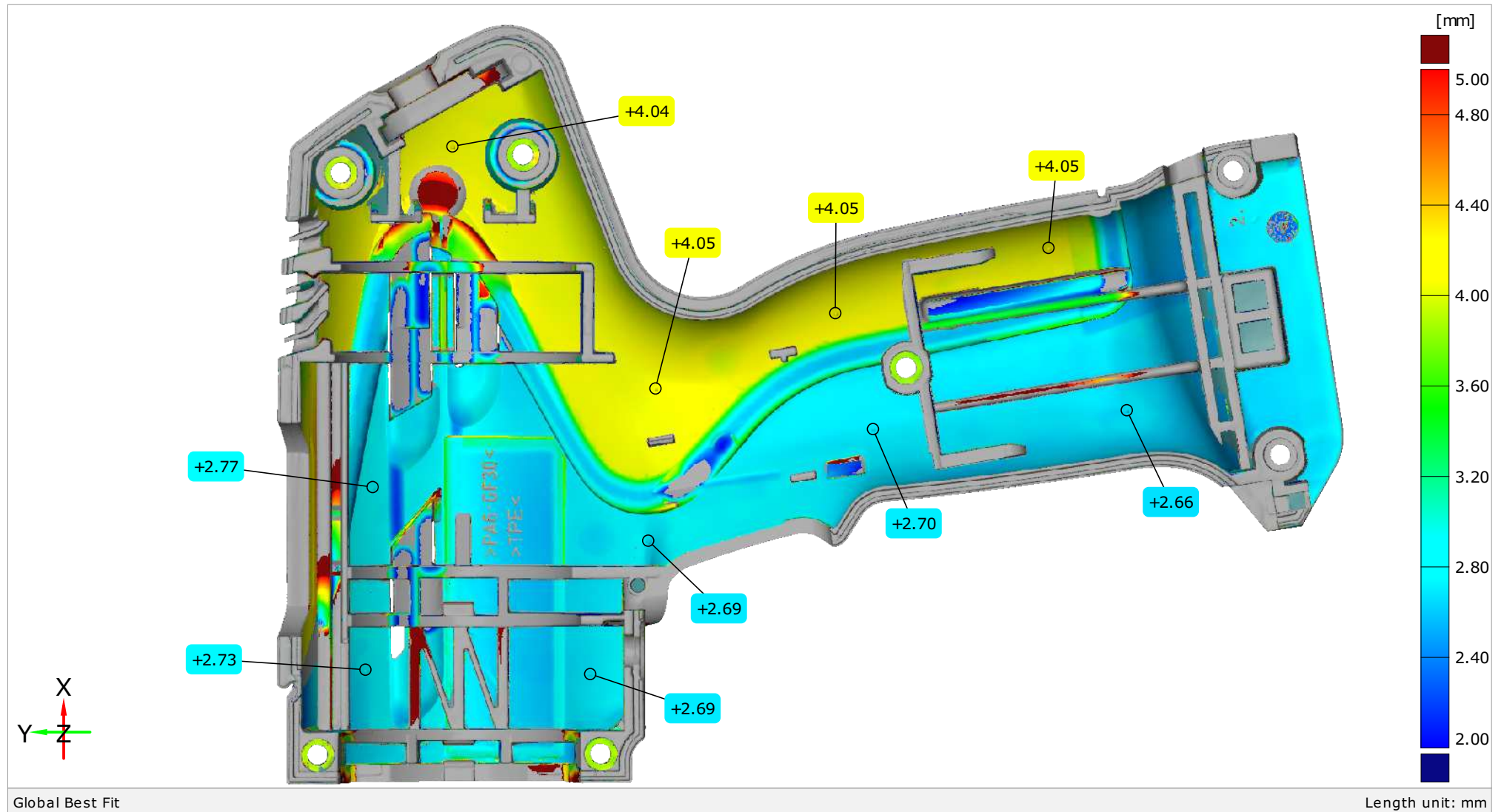

Global Best Fit

Length unit: mm

Demonstration Data Drill Cover 1 -/- 1

10/18

Material Thickness - Inspection Points

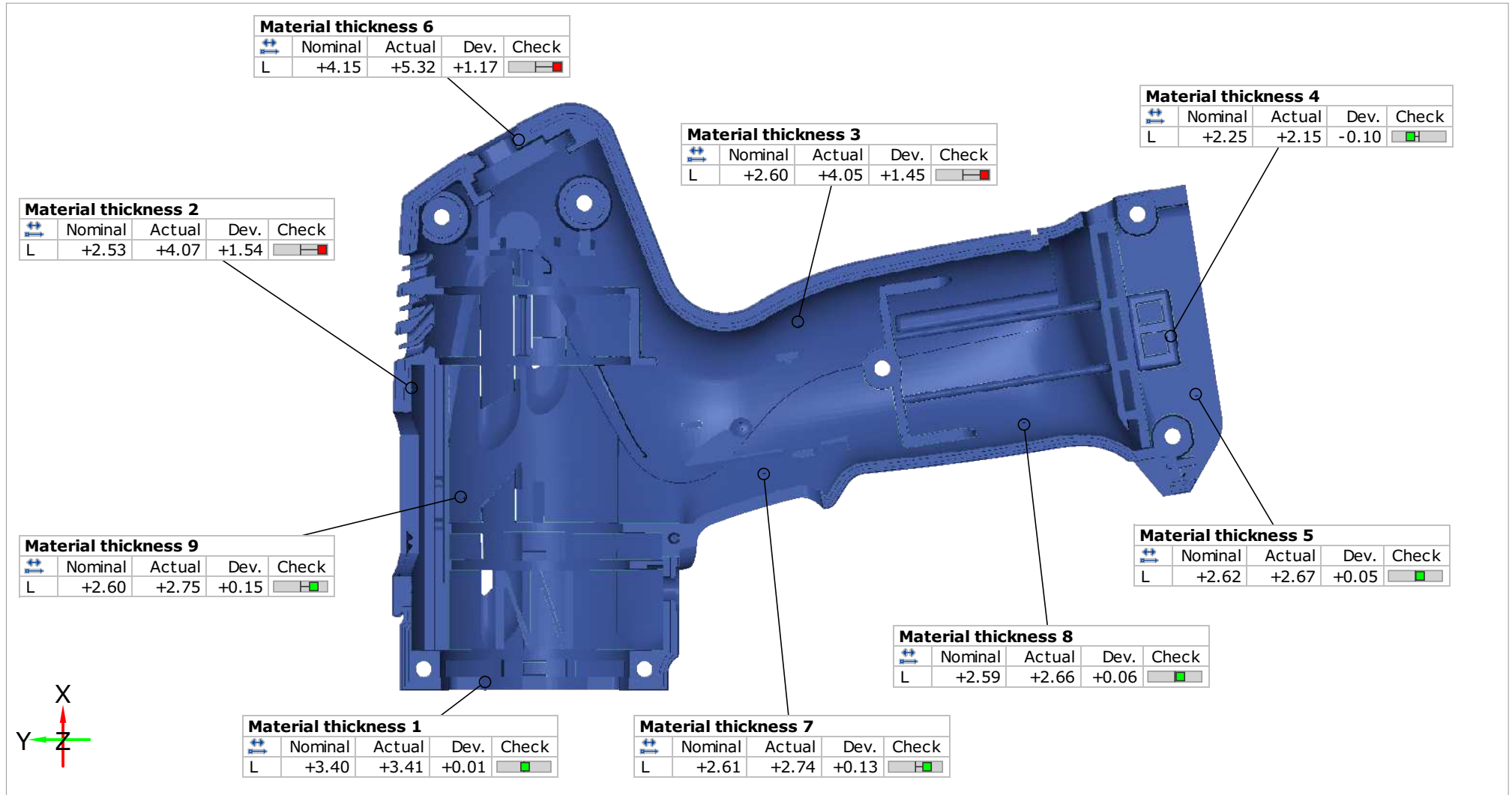

Global Best Fit

Length unit: mm

Circle Inspection - Position and Diameter

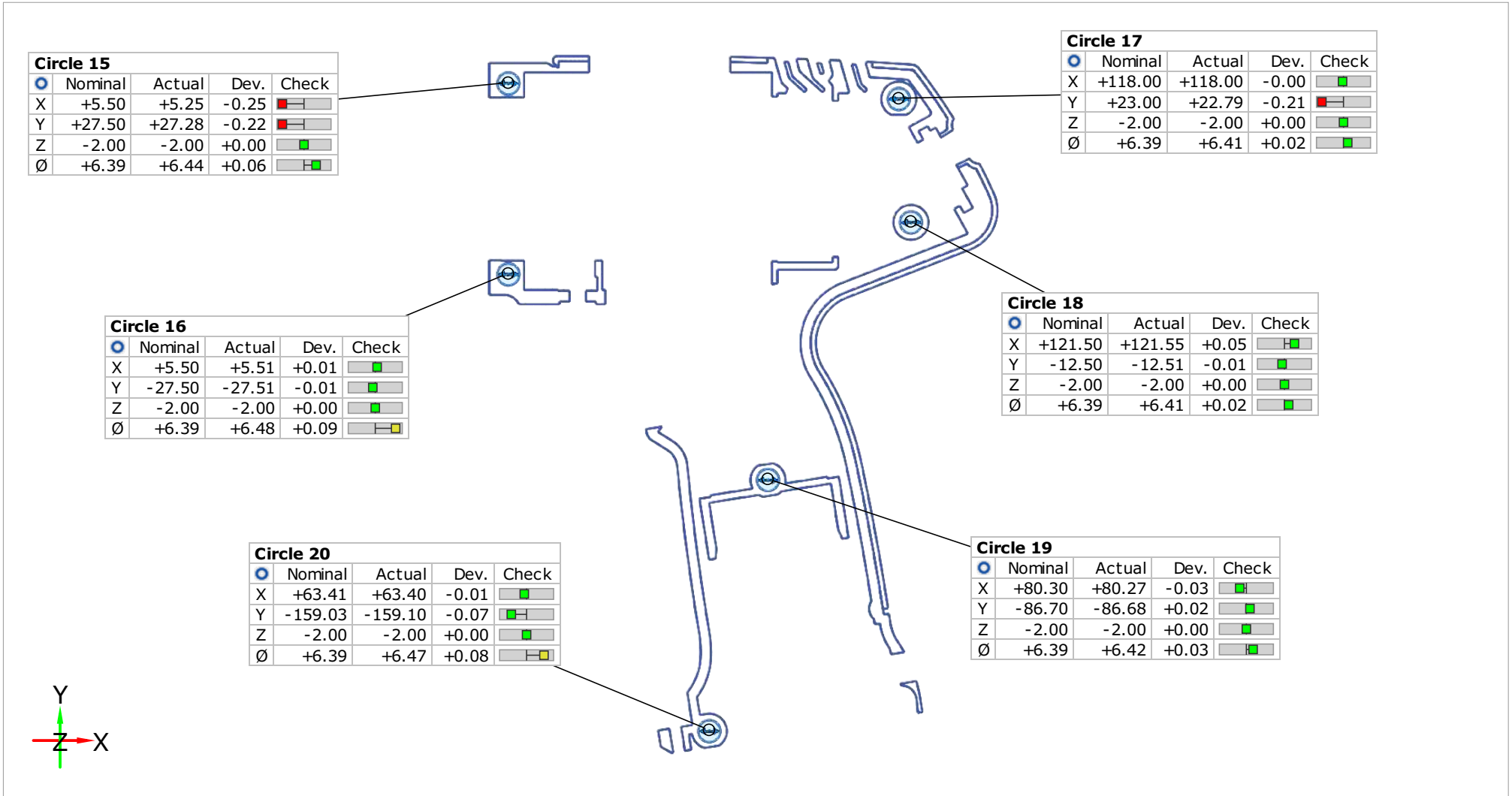

Global Best Fit

Length unit: mm

Circle Inspection - Position and Diameter

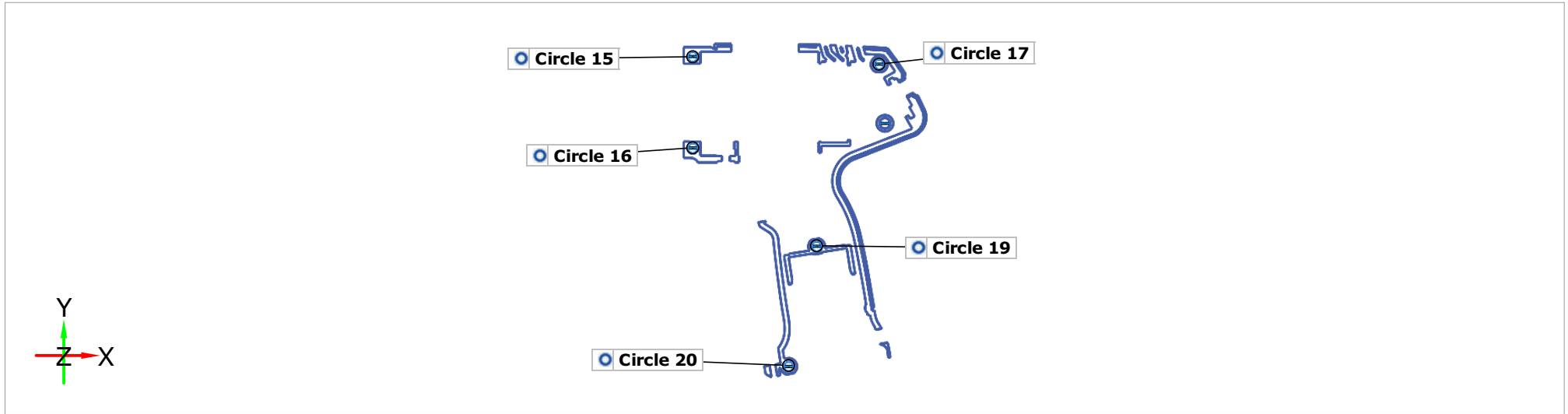

Element	Property	Nominal	Actual	Tol -	Tol +	Dev	Check	Out
Circle 15	X	+5.50	+5.25	-0.10	+0.10	-0.25		-0.15
Circle 15	Y	+27.50	+27.28	-0.10	+0.10	-0.22		-0.12
Circle 15	Z	-2.00	-2.00	-0.10	+0.10	+0.00		
Circle 15	D	+6.39	+6.44	-0.10	+0.10	+0.06		
Circle 16	X	+5.50	+5.51	-0.10	+0.10	+0.01		
Circle 16	Y	-27.50	-27.51	-0.10	+0.10	-0.01		
Circle 16	Z	-2.00	-2.00	-0.10	+0.10	+0.00		
Circle 16	D	+6.39	+6.48	-0.10	+0.10	+0.09		
Circle 17	X	+118.00	+118.00	-0.10	+0.10	-0.00		
Circle 17	Y	+23.00	+22.79	-0.10	+0.10	-0.21		-0.11

Global Best Fit

Length unit: mm

Circle Inspection - Position and Diameter

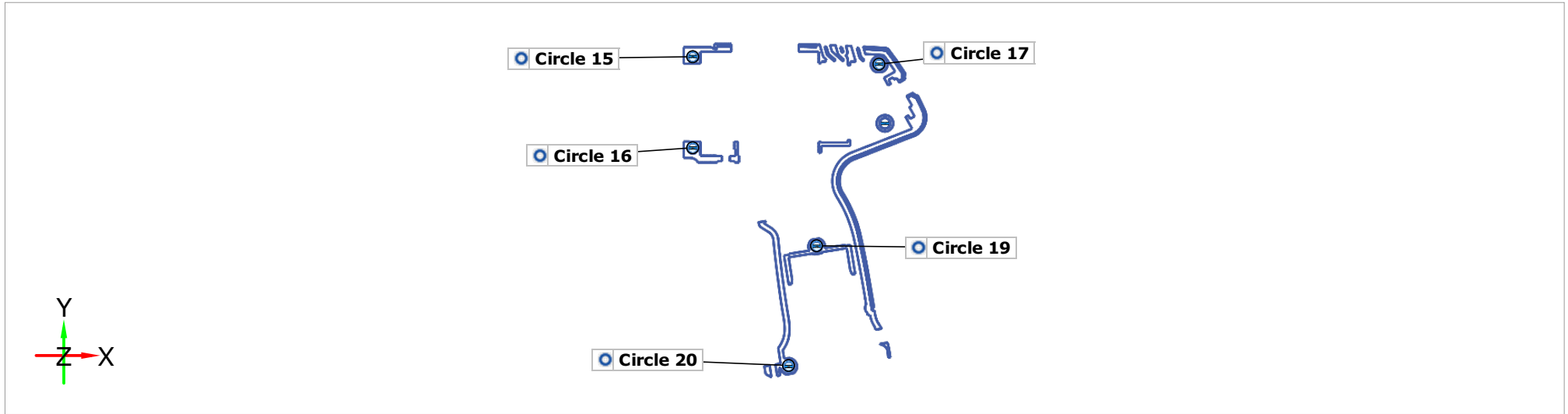

Element	Property	Nominal	Actual	Tol -	Tol +	Dev	Check	Out
Circle 17	Z	-2.00	-2.00	-0.10	+0.10	+0.00		
Circle 17	D	+6.39	+6.41	-0.10	+0.10	+0.02		
Circle 19	X	+80.30	+80.27	-0.10	+0.10	-0.03		
Circle 19	Y	-86.70	-86.68	-0.10	+0.10	+0.02		
Circle 19	Z	-2.00	-2.00	-0.10	+0.10	+0.00		
Circle 19	D	+6.39	+6.42	-0.10	+0.10	+0.03		
Circle 20	X	+63.41	+63.40	-0.10	+0.10	-0.01		
Circle 20	Y	-159.03	-159.10	-0.10	+0.10	-0.07		
Circle 20	Z	-2.00	-2.00	-0.10	+0.10	+0.00		
Circle 20	D	+6.39	+6.47	-0.10	+0.10	+0.08		

Global Best Fit

Length unit: mm

Circle Inspection - Hole Pattern

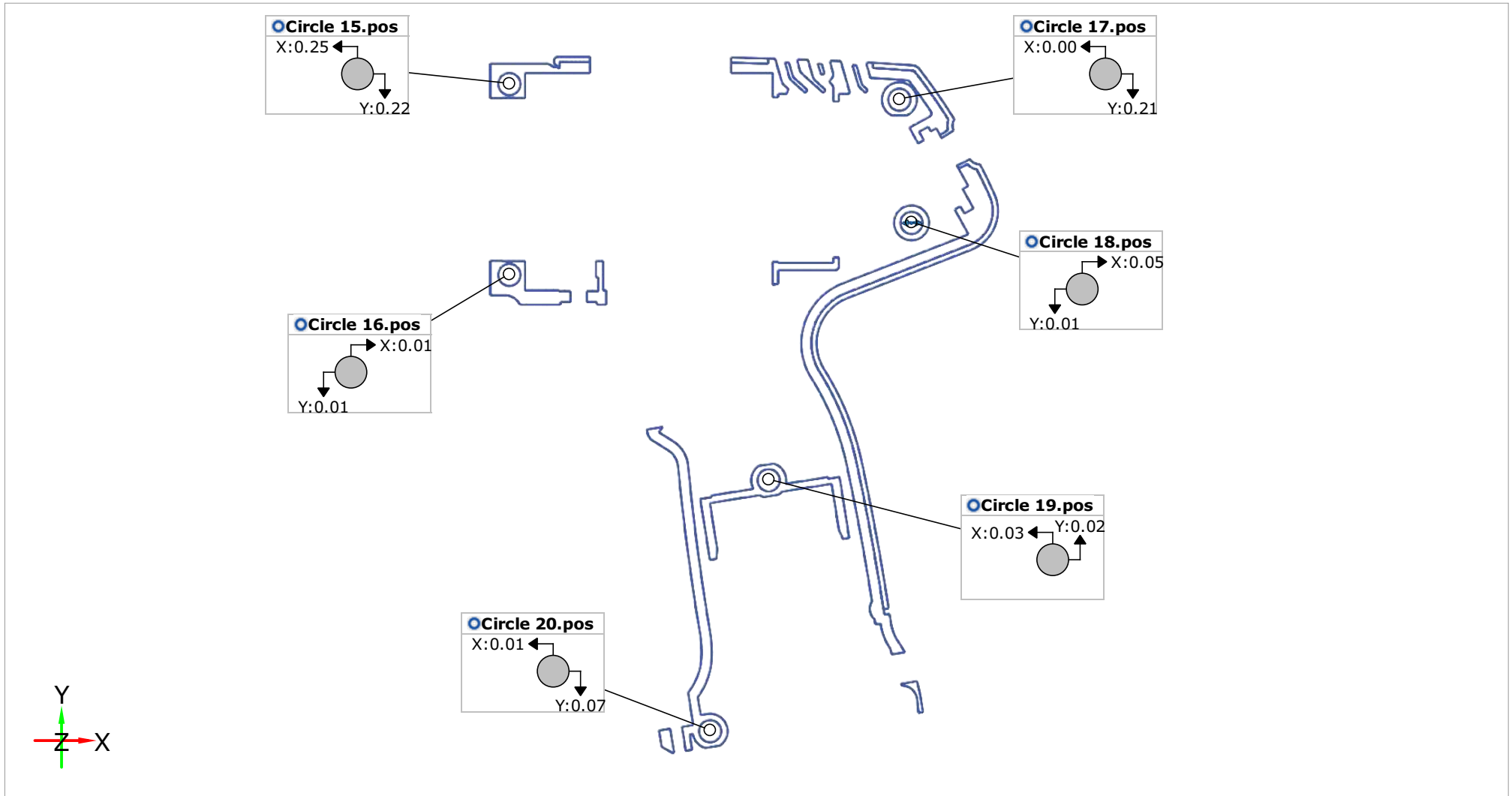

Global Best Fit

Length unit: mm

Demonstration Data Drill Cover 1 -/ 1

15/18

2D Inspection - Scalar Dimensions

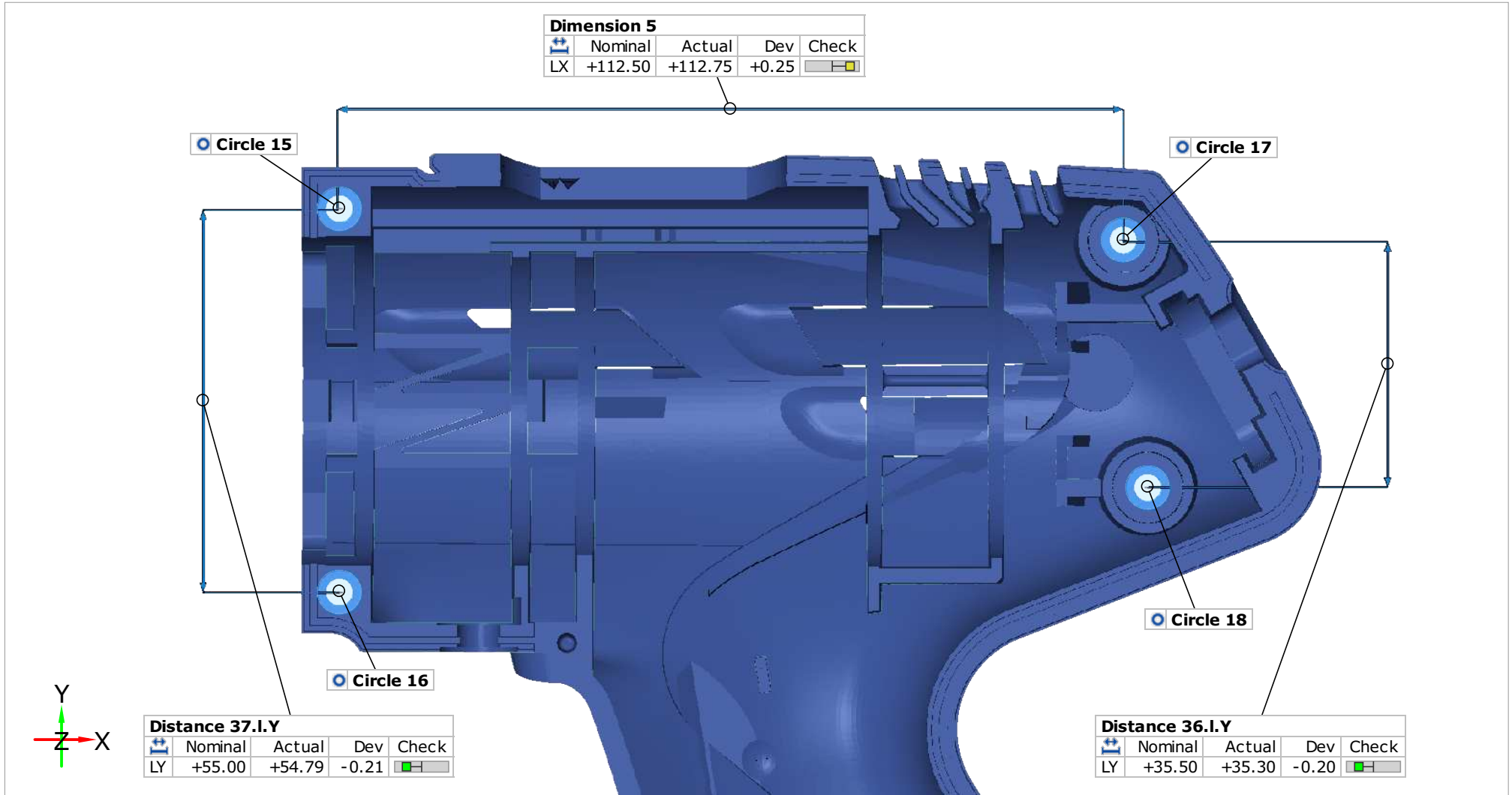

Global Best Fit

Length unit: mm

Demonstration Data Drill Cover 1 -/- 1

16/18

GD&T Cylindricity

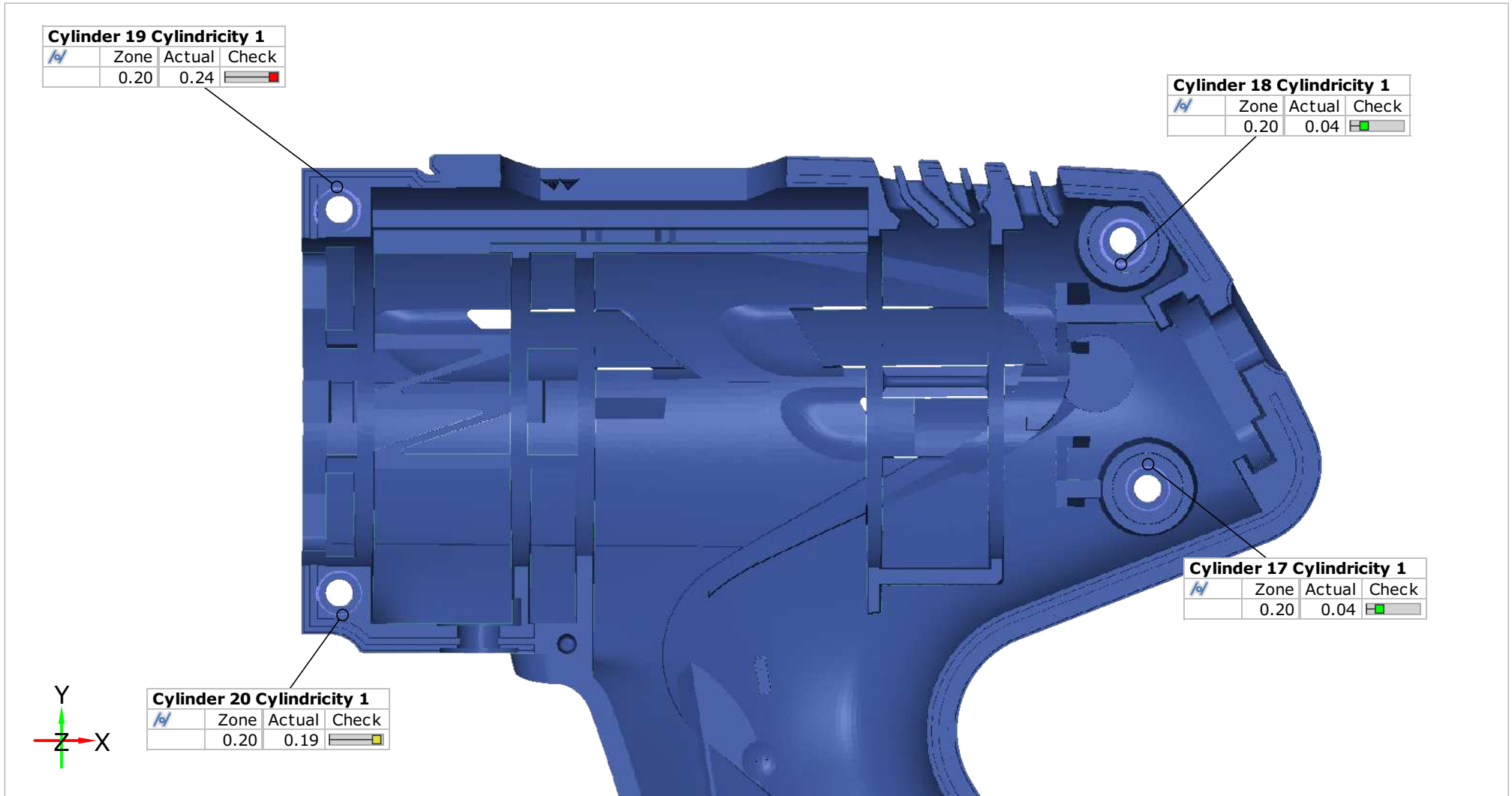

Global Best Fit

Length unit: mm

GD&T Flatness

